

Mar 14, 2024

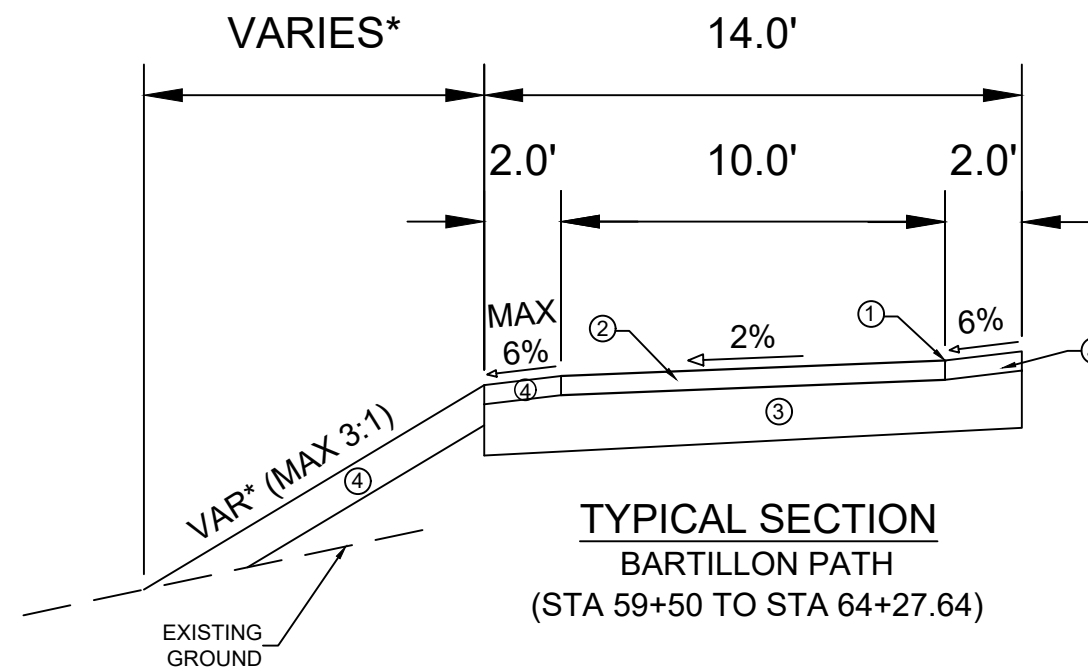
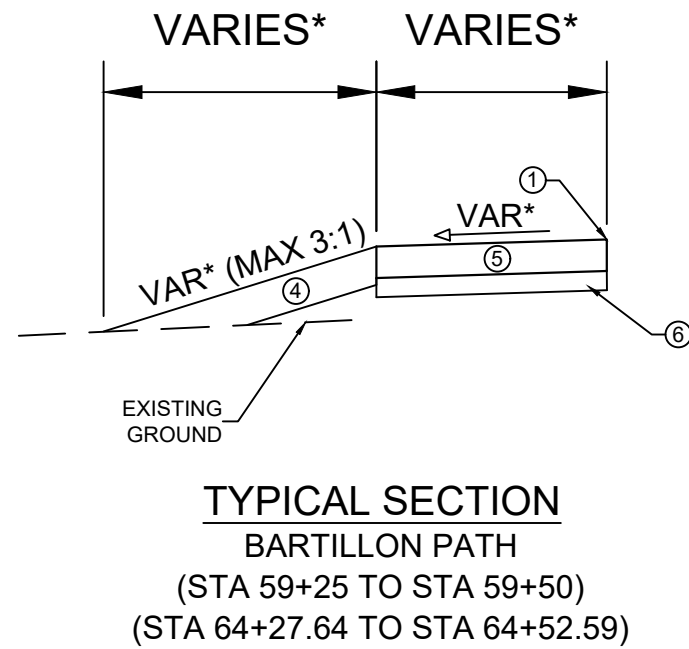

**NOTES:**

\* SEE PLAN AND CROSS SECTIONS FOR DETAILS AND DIMENSIONS

- ① POINT REFERRED TO ON PROFILE
- ② 3.0" H.M.A. PAVEMENT- TYPE 4 LT 58-28 S
- ③ 8" CRUSHED AGGREGATE BASE COURSE GRADATION 2
- ④ 6" TOPSOIL, SEED AND EROSION MATTING
- ⑤ 5" CONCRETE SIDEWALK
- ⑥ 3" SELECT FILL

MARK	REVISION	DATE	BY
14890	Designed By: EEA	Date: 03/08/2024 9:00 AM	Scale:
			D-1

14890  
MADISON, WI  
CONTRACT NO: 8757

TYPICAL SECTIONS  
BARTILLON PATH  
M:\DESIGN\Projects\14890\CAD\Streets\14890EN-Details\_BidSet.dwg



14890  
D-1

# N. STOUGHTON ROAD

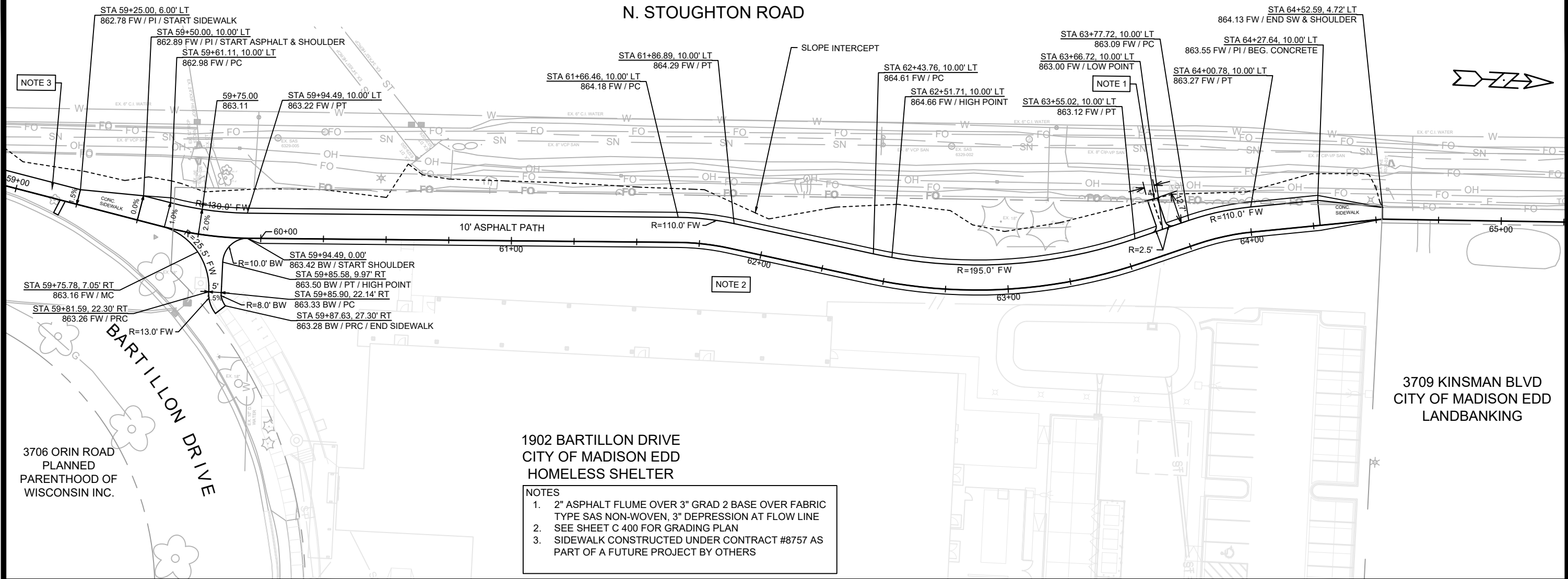

NOTE 3

NOTE 1

NOTE 2

**1902 BARTILLON DRIVE  
CITY OF MADISON EDD  
HOMELESS SHELTER**

**NOTES**

- 2" ASPHALT FLUME OVER 3" GRAD 2 BASE OVER FABRIC TYPE SAS NON-WOVEN, 3" DEPRESSION AT FLOW LINE
- SEE SHEET C 400 FOR GRADING PLAN
- SIDEWALK CONSTRUCTED UNDER CONTRACT #8757 AS PART OF A FUTURE PROJECT BY OTHERS

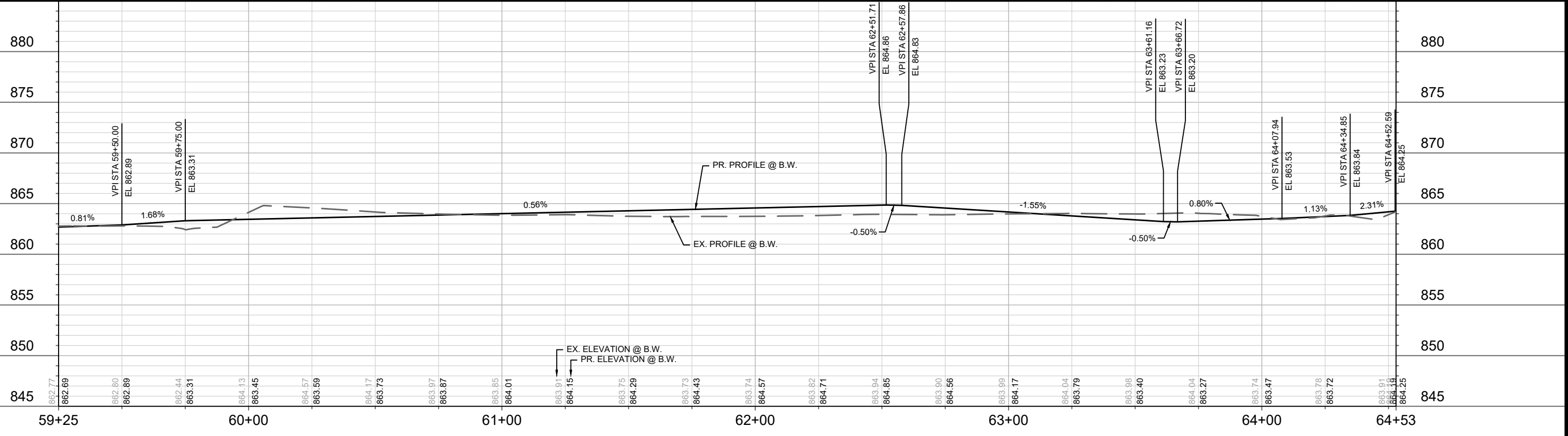

DATE	BY
REVISION	
MARK	
Designed By: EEA	Date: 03/07/2024 2:30 PM
14890	P-1

14890  
MADISON, WI  
CONTRACT NO: 8757

PLAN & PROFILE - BARTILLON PATH  
BARTILLON PATH  
M:\DESIGN\Projects\14890\CAD\Streets\14890EN-PnP.dwg



14890  
P-1

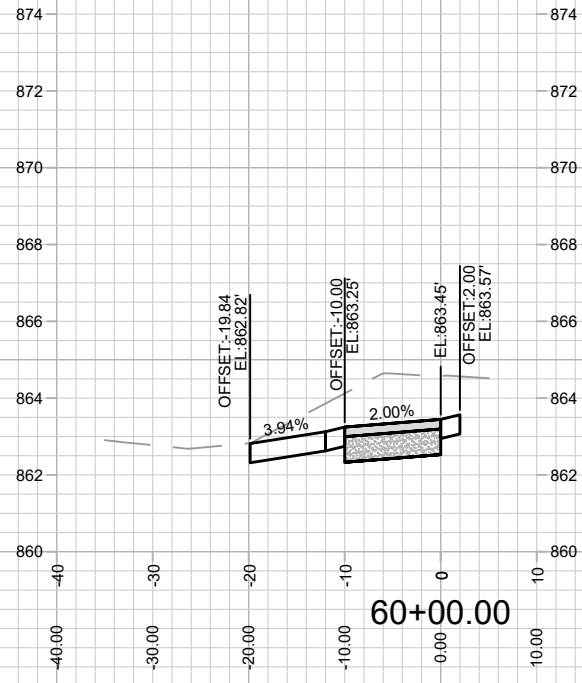
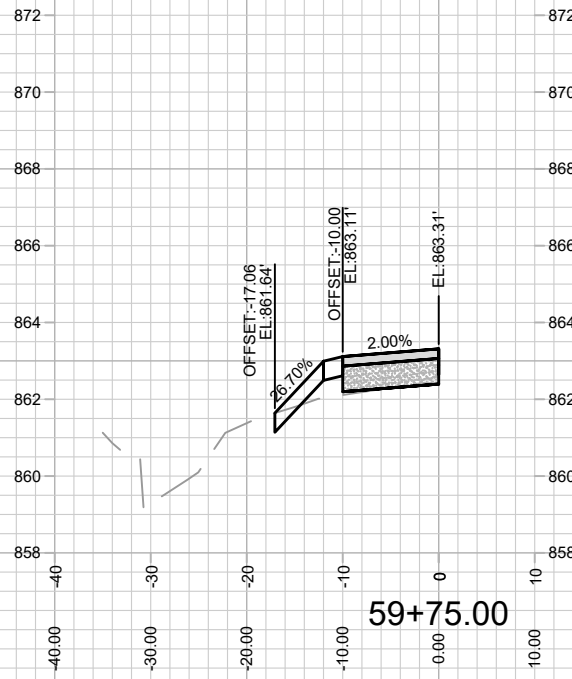
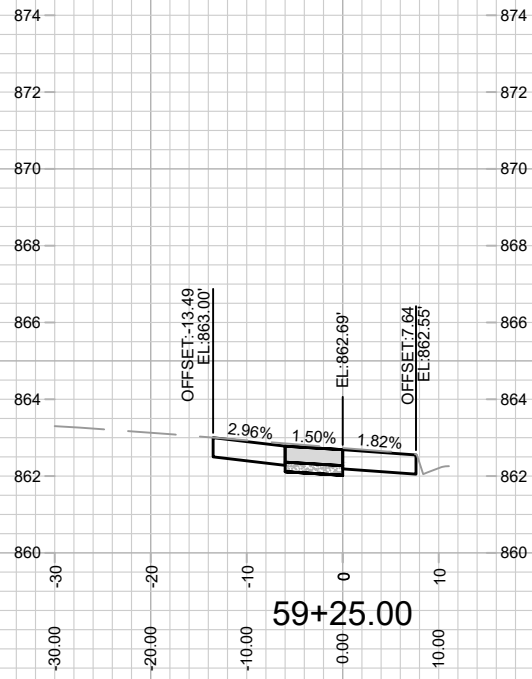
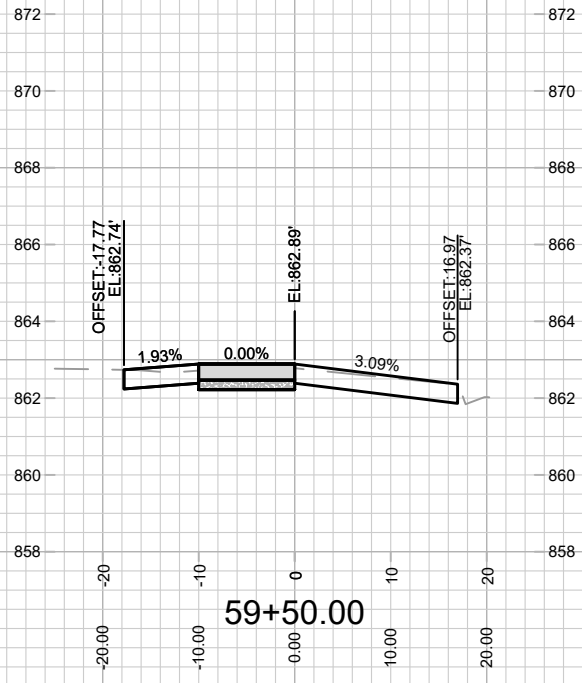

14890  
X-1

CROSS SECTIONS - BARTILLON PATH  
BARTILLON PATH

14890  
MADISON, WI

CONTRACT NO: 8757

MARK	REVISION	DATE	BY
14890	Designed By: EEA	Date: 3/8/2024 11:00 AM	Scale: 1" = 20'
			X-1

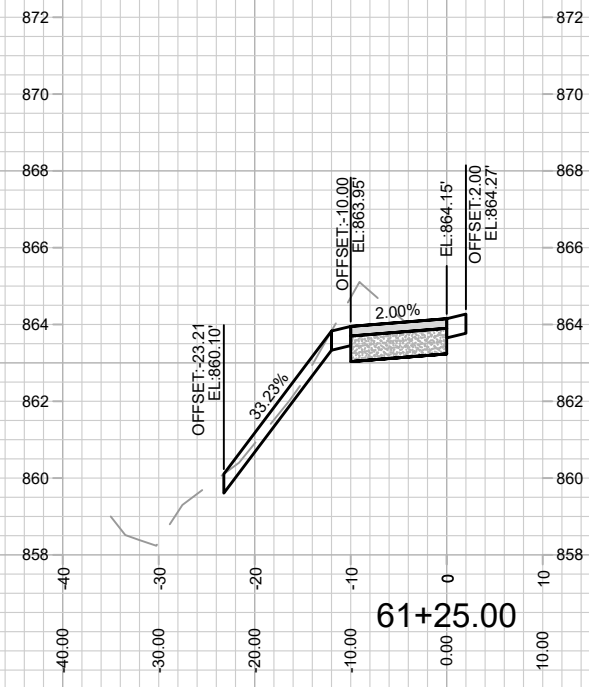
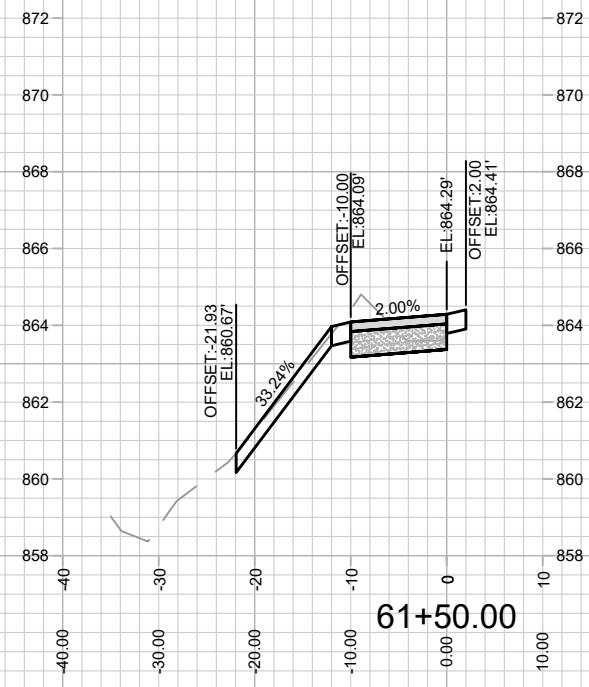
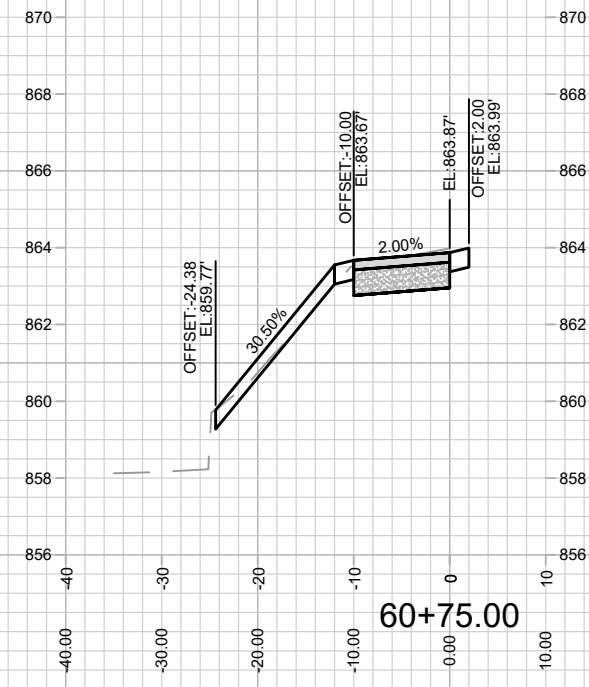
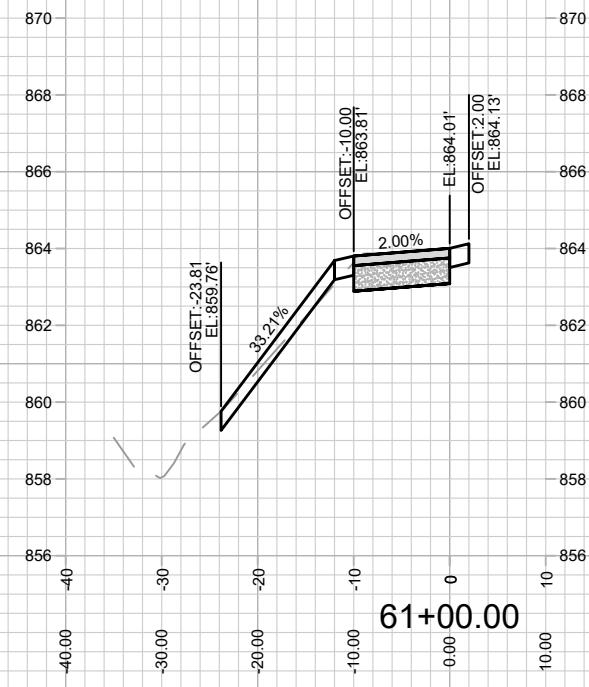
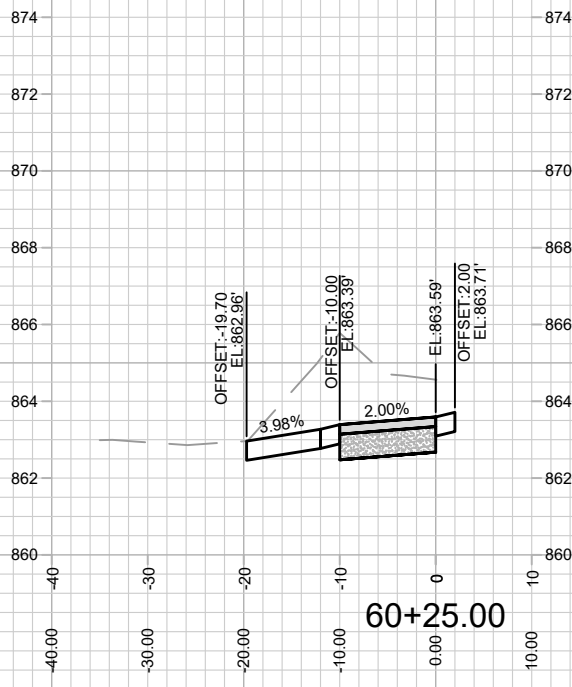
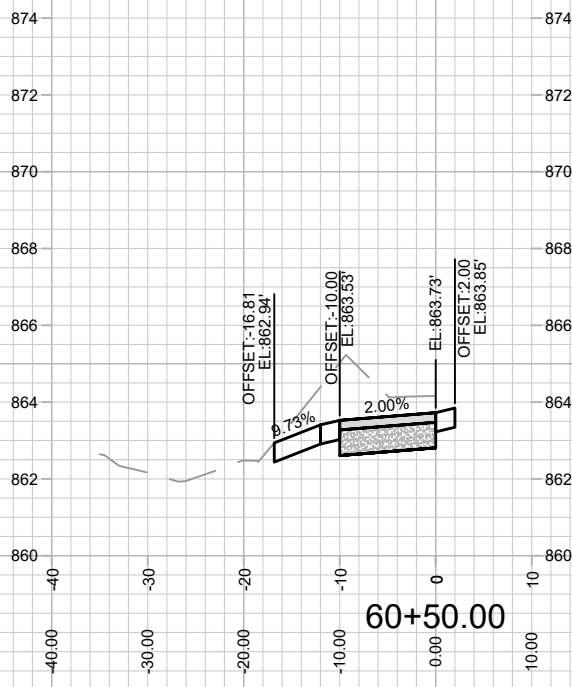

MARK	REVISION	DATE	BY

14890  
MADISON, WI  
8757  
CONTRACT NO:

CROSS SECTIONS - BARTILLON PATH  
BARTILLON PATH  
M:\DESIGN\Projects\14890\CAD\Streets\14890EN-XSections.dwg



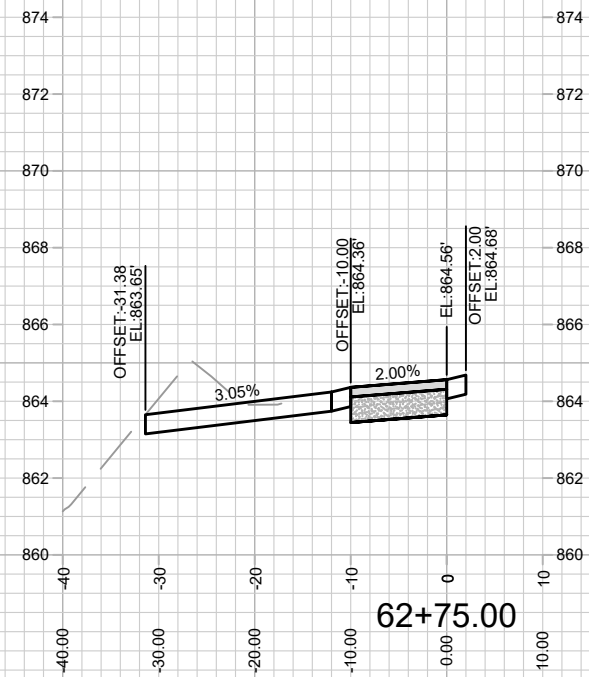
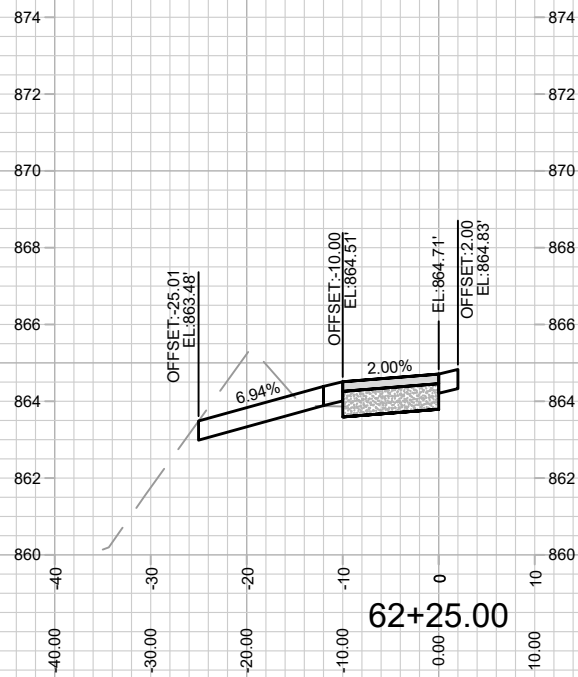
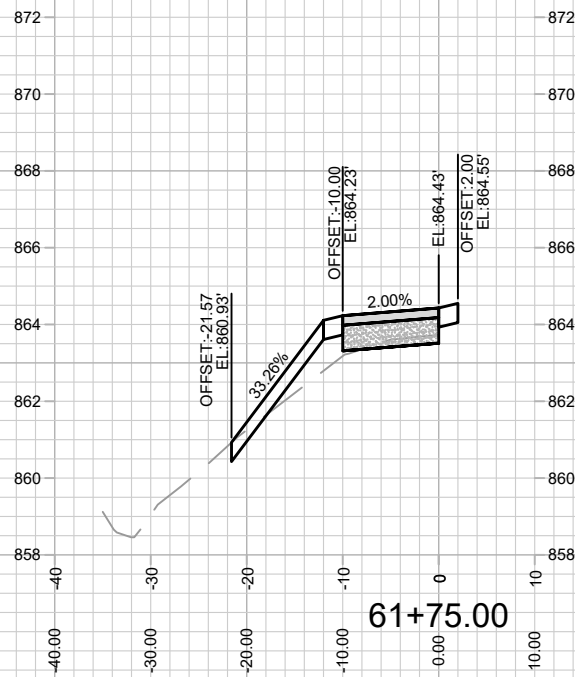
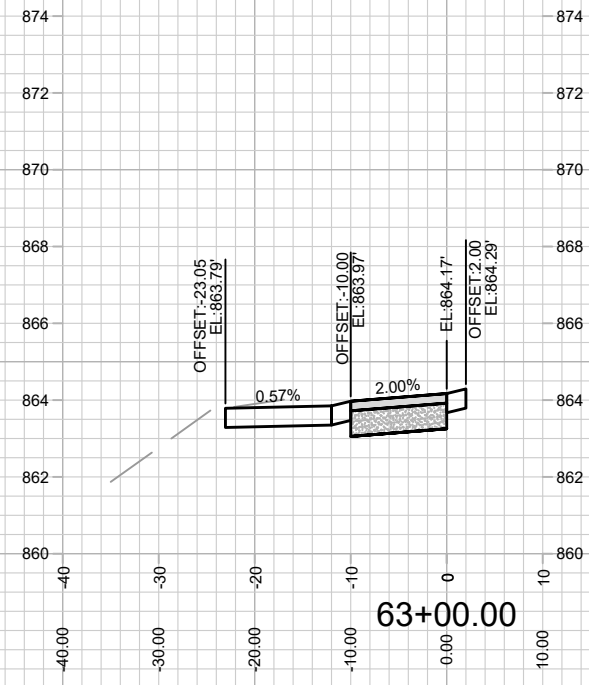
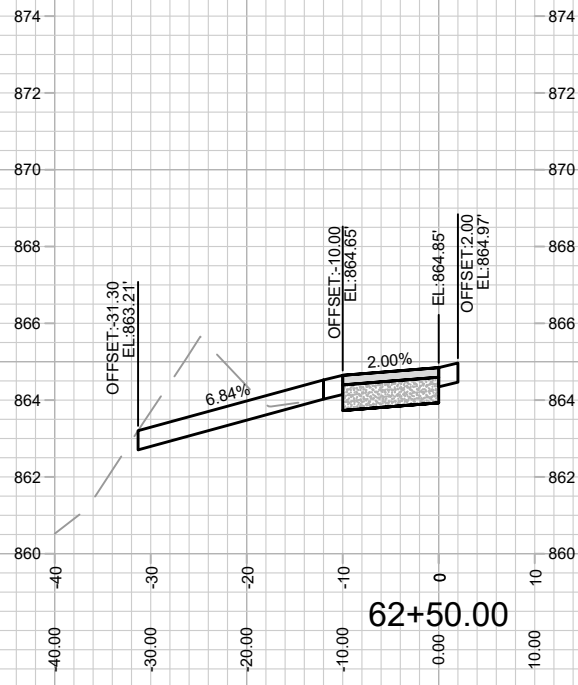
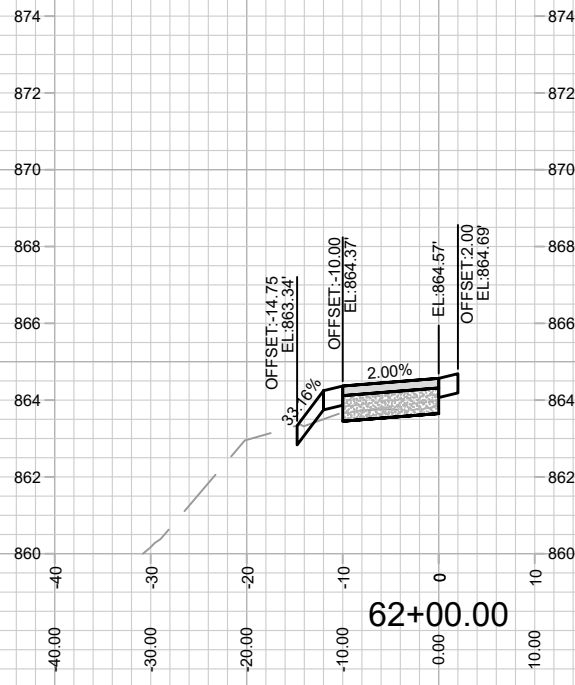

MARK	REVISION	DATE	BY

14890  
MADISON, WI  
8757  
CONTRACT NO:

CROSS SECTIONS - BARTILLON PATH  
BARTILLON PATH  
M:\DESIGN\Projects\14890\CAD\Streets\14890EN-XSections.dwg



14890  
X-3

Designed By: EEA  
Date: 3/8/2024 11:00 AM  
Scale: 1" = 20'  
14890  
X-3

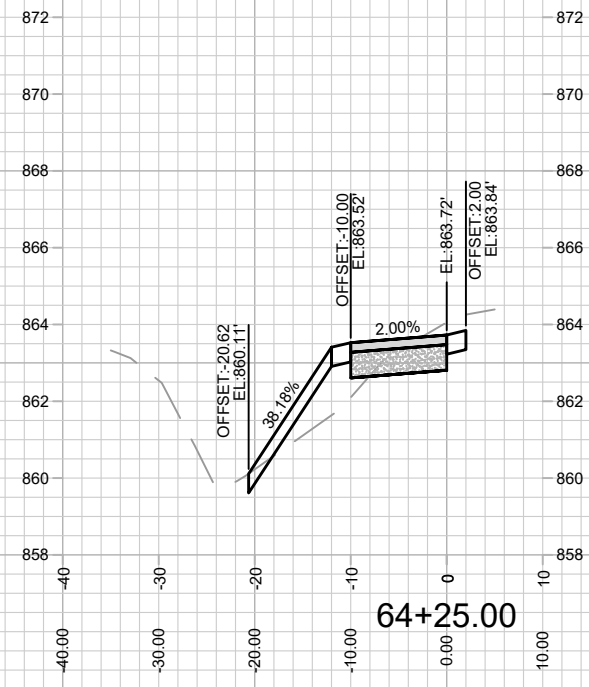
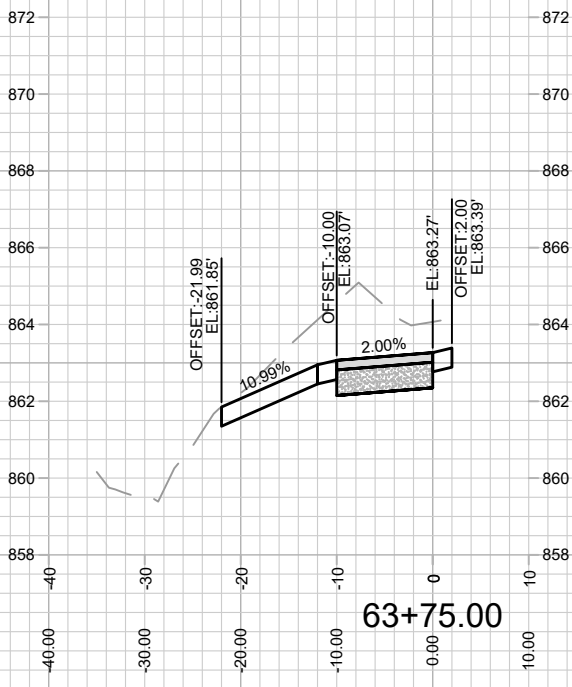
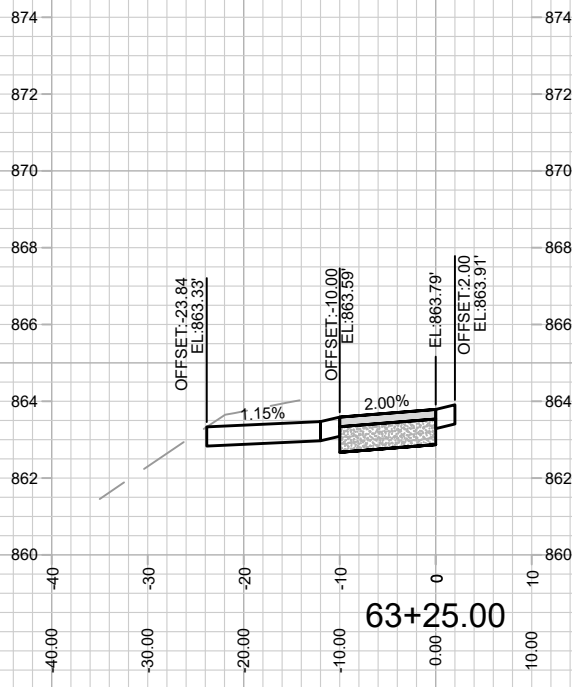
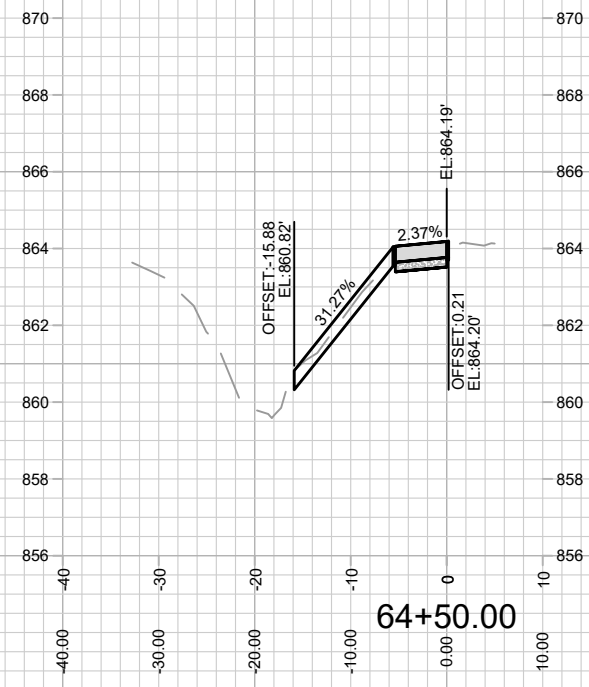
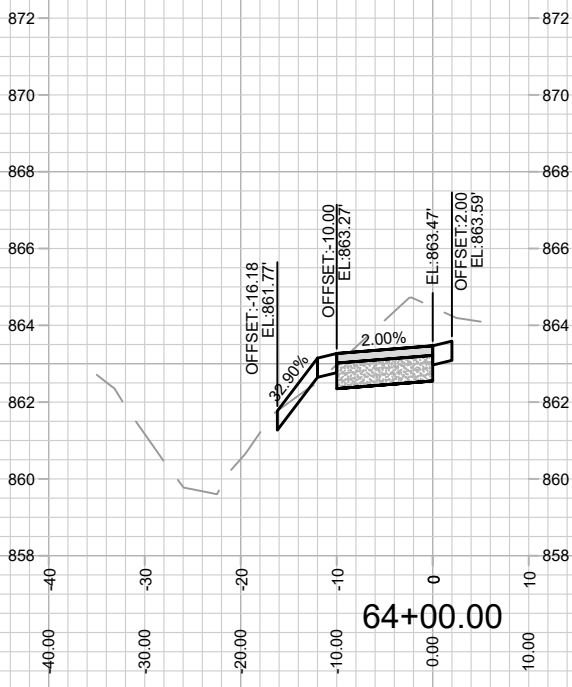
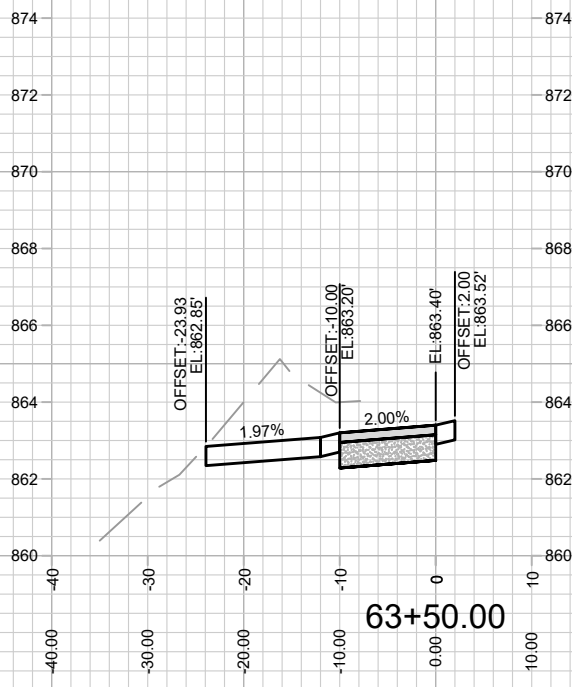

MARK	REVISION	DATE	BY

Designed By: EEA Date: 3/8/2024 11:00 AM Scale: 1" = 20'

14890  
MADISON, WI  
8757  
CONTRACT NO:

CROSS SECTIONS - BARTILLON PATH  
BARTILLON PATH  
M:\DESIGN\Projects\14890\CAD\Streets\14890EN-XSections.dwg



14890  
X-4